

Outbound B Reorganization: 367(a) & 367(b) Overlap

Copyright © 2006 Andrew Mitchel LLC
International Tax Services
www.andrewmitchel.com

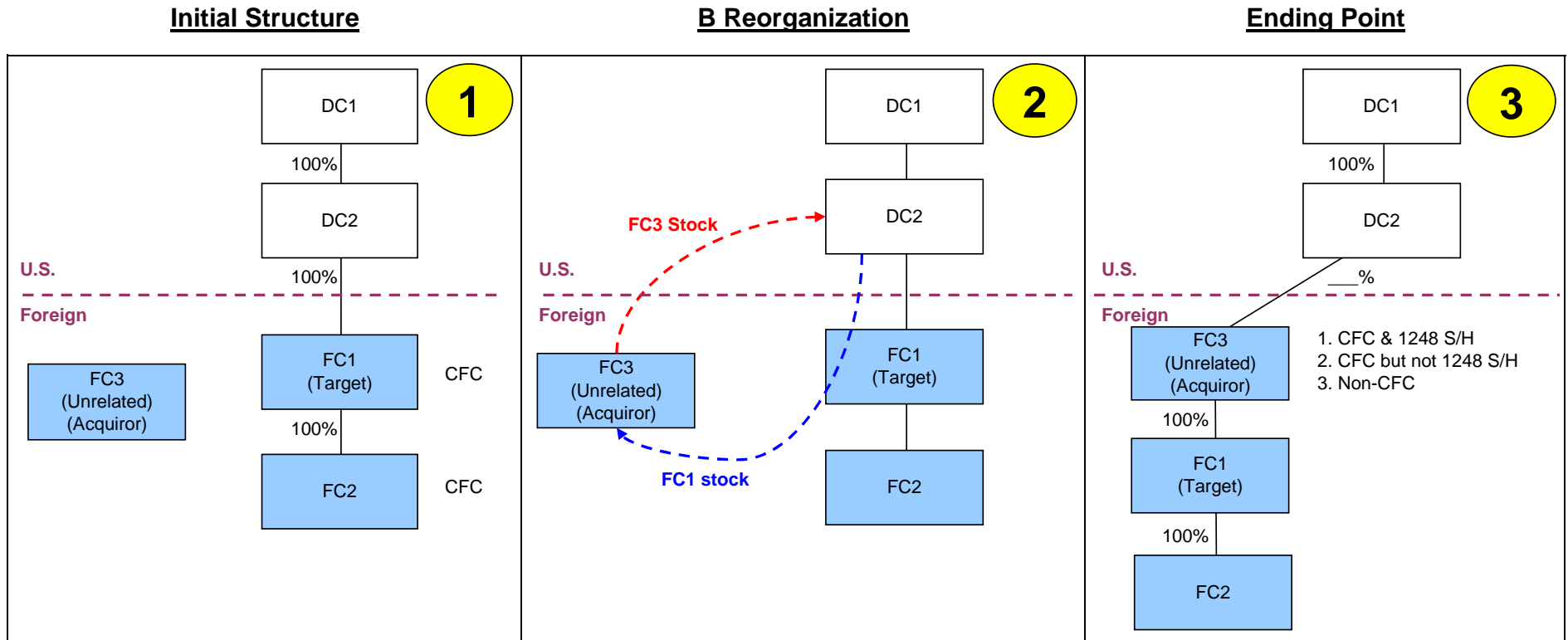

Section 367(a): If DC2 receives less than 5% of the stock of FC3, then no gain will be required to be recognized under section 367(a). If DC2 receives 5% or more of the stock of FC3, then DC2 must file a gain recognition agreement ("GRA") to avoid gain. If gain is recognized under section 367(a), then 367(b) does not apply.

Section 367(b): The exchange is subject to section 367(b) because it is described in section 354 and the status of foreign corporations (FC1 & FC3) as corporations are relevant in determining tax attributes. The general rule of section 367(b) is that a foreign corporation is considered to be a corporation except to the extent provided in the regulations.

If, after the reorganization, FC3 is a CFC and DC2 is a section 1248 shareholder of FC3 (DC2 owns >10% of the stock of FC3), then there are no exceptions to corporate treatment and no income inclusion is required under section 367(b). If, however, FC3 is not a CFC or DC2 is not a section 1248 shareholder with respect to FC3, then DC2 must include in income as a deemed dividend the section 1248 amount attributable to the FC1 stock.